

Splashwall

COMPOSITE INSTALLATION

Contents

1.	Inspection	3
2.	Storage	3
3.	Handling	3
4.	Planning & Preparation	3
5.	Tools & Fixings	3
6.	Panels	4
7.	Accessories	4
8.	Fitting Tips	4
9.	Two Sided Shower Installation	6
10.	Three Sided Shower Installation	7
11.	Straight Jointing Details	8
12.	Bottom & Skirting Details	8
13.	Window, Door & Finishing Details	9
14.	Cleaning	9

1. Inspection

Panels must be thoroughly inspected upon receipt for damage or visible defects. The panels are supplied with a protective clear film to the decorative face, this should be peeled back to check for damage or discrepancies in colour where necessary then replaced to provide protection during installation.

Do not install panels that you find to be defective.

Once the panels or profiles have been cut or installed we regard this as an acceptance of their quality and suitability for purpose and therefore we cannot accept any subsequent claims for faults or damage.

2. Storage

Panels should always be stored flat to avoid bowing.

- Panels should never be stored outside.
- Wetwall Panel Adhesive should be stored in cool dry conditions between 5 - 25°C.

3. Handling

Composite panels can have extremely sharp edges and we advise that suitable gloves be worn for protection when handling and installing.

4. Planning & Preparation

Before you undertake any type of installation it is always wise to carry out a degree of planning that might save you a lot of time and grief later on. Below are some points that may help.

4.1 Panel Lining Surface

Composite panels must be fitted to a continuous surface such as plaster board, existing tiling, chipboard & plywood sheathing and tile backers providing the surface is sound, plumb and level.

Some surfaces do require pre-treatment before installation, tiles should be de-greased and fresh plaster should be sealed with a proprietary PVA sealer.

4.2 Services

Necessary pipe work should be fitted and short tails left where they are to pass through panels.

Electrical cabling should be in place and routed to avoid subsequent fixing points.

Shower trays and baths should be fitted in position, these should also be sealed in accordance with the manufacturers recommendations.

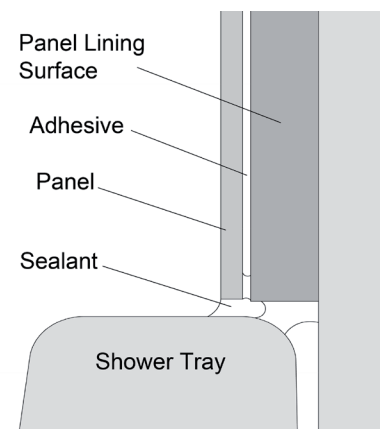

5. Tools & Fixings

Tools and fixings that you will need to install the panels include –

- Jigsaw, circular saw or router
- Screwdriver
- Mastic Gun
- Measuring tape & pencil
- Masking Tape
- Panel Adhesive
- Silicone Sealant

6. Panels

All panels are 3mm thick overall and are supplied with clear plastic protective film to the decorative face.

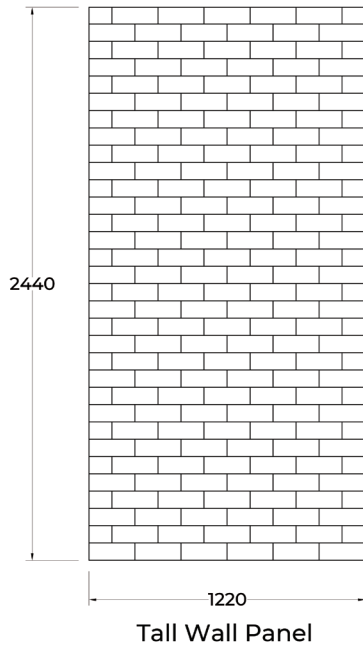

	Width/Height	Weight (app.)
Tall Wall Panel	1220mm x 2440mm	14.5Kg
Long Wall Panel	2440mm x 1220mm	14.5Kg

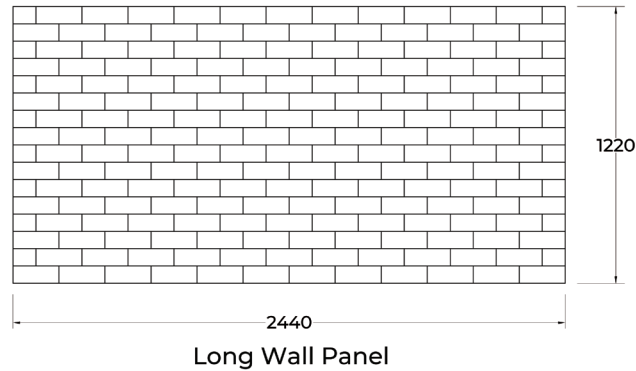

7. Accessories

Composite profiles come in 2440mm lengths and are available either colour co-ordinated to the Composite or in a polished silver finish. It is recommended that Wetwall Silicone Sealant and Panel Adhesive is used for all installations.

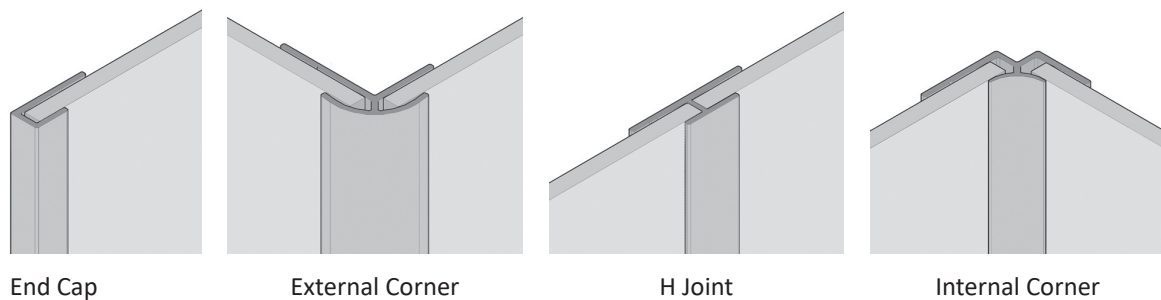

8. Sizing & Cutting

Before cutting you should make sure that you have taken into account any allowances for profiles that are to be used which are shown below.

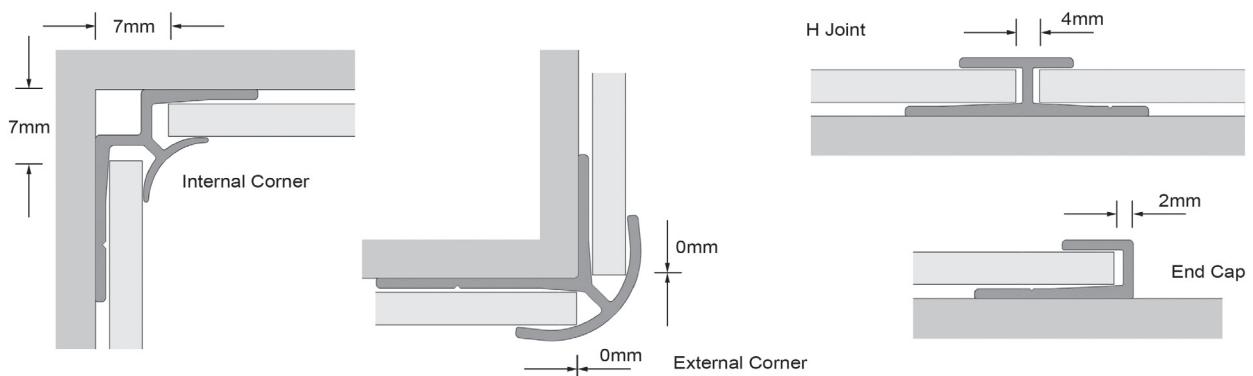

8. Sizing & Cutting (contd.)

When cutting the panels to width and height using a jigsaw with an 'up-cut' blade or with a circular saw then the decorative side of the panel should be facing down.

If cutting using a hand saw then the decorative side should be facing up.

The panels should be well supported from beneath along the cut length and clamped in place where required.

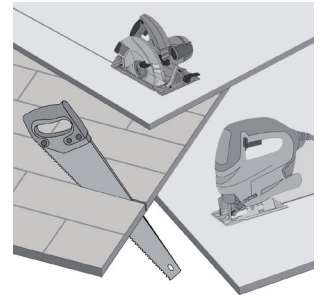

8.1. Tile Groove Alignment

The composite panels are produced with a tile effect embossed into the face but due to the manufacturing and trimming processes it is not always possible to ensure that the pattern is identical on every panel.

It is therefore sometimes necessary to trim the panels prior to installation to ensure that the tile groove lines are aligned and square to any edges that are to be jointed.

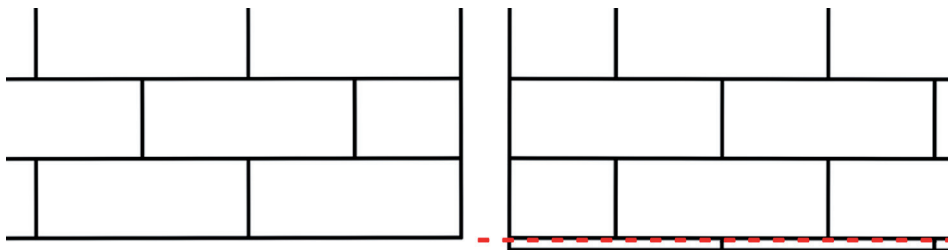

8.2 Cut-Outs

Shaped cut-outs can be formed by drilling 8mm diameter holes in the corners of the required shape and then cutting between the holes using a jigsaw with a fine toothed blade. It is important that the panel is supported at all times.

A radius of at least 4mm must be left in the corners of all cut-outs failure to do this can lead to stress cracking.

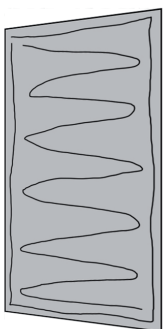
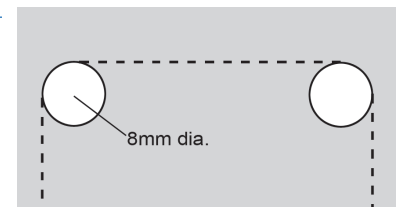

8.3 Adhesive application

When applying adhesive to the back of the panel to be fitted to a continuous surface we would recommend a 6mm bead applied just inside the perimeter and then zig-zagged down the middle.

8.4 Masking

Preparing the panels with masking tape before sealing can save a lot of time cleaning off excess sealant later on in the installation, especially at the bottom joints where a larger covered seal will be formed.

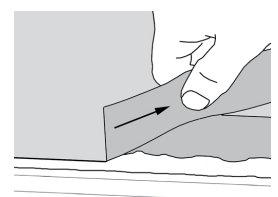

8.5 Sealing at the bottom

A 3mm - 4mm gap must be left between the bottom of the panel and top of the shower tray or bath, this can be achieved by using packers when fixing panels. The gaps should then be sealed ensuring that the silicone is forced into the void.

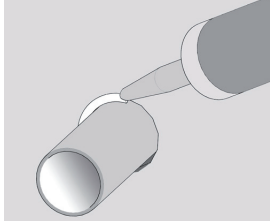
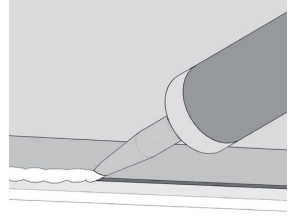

8.6 Sealing at apertures & Cut-outs

A clearance gap of 2-3mm all around should be allowed where pipes or fittings come through the panel even where collars are to be fitted. The gap should then be filled with sealant.

8.7 Fitting through Composite Panels

Fittings such as shower attachments and screens can be fixed directly through the panels into the panel lining surface using suitable fixings. Heavier items will need solid fixing points behind the panels to provide the necessary support, these should be considered when planning your installation.

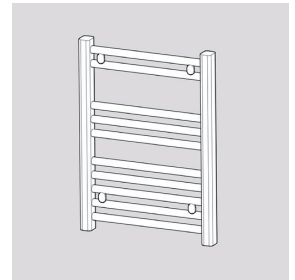

9. Two Sided Shower Installation – Steps

The following steps assume that the panel lining surface has been prepared and the panels and trims have been cut to the required size and that they have been dry fitted to check assembly.

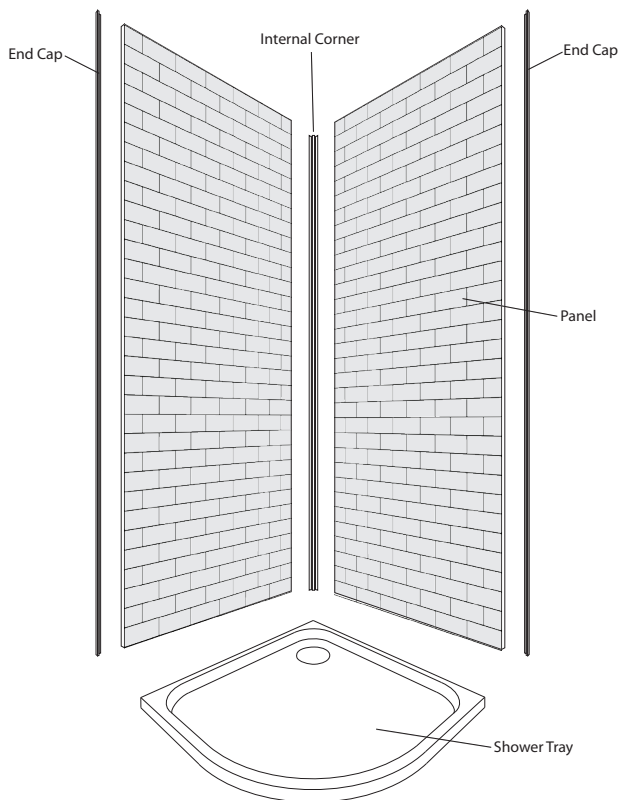

1. Peel back the protective film about 25mm from the vertical edge of the panel. Apply a bead of sealant into one side of the internal corner profile and fit onto the exposed edge of the first panel.
2. Repeat this on the opposite edge of the panel if an End Cap profile is required and fit the End Cap to the edge of the panel using a bead of sealant.
3. A 3-4mm gap should be left between the bottom of the panel and the top of the shower tray, this can be achieved by using packers which will be removed before sealing.
4. Apply adhesive to the back of the panel as detailed in Fitting Tips then position the panel against the wall applying even pressure over the surface to ensure a good bond.
5. Repeat steps 2-5 for the second panel.
6. Seal the bottom of the panels and any apertures required as detailed in the fitting tips section.

10. Three Sided Shower Installation – Steps

The following steps assume that the panel lining surface has been prepared and the panels and trims have been cut to the required size and that they have been dry fitted to check assembly.

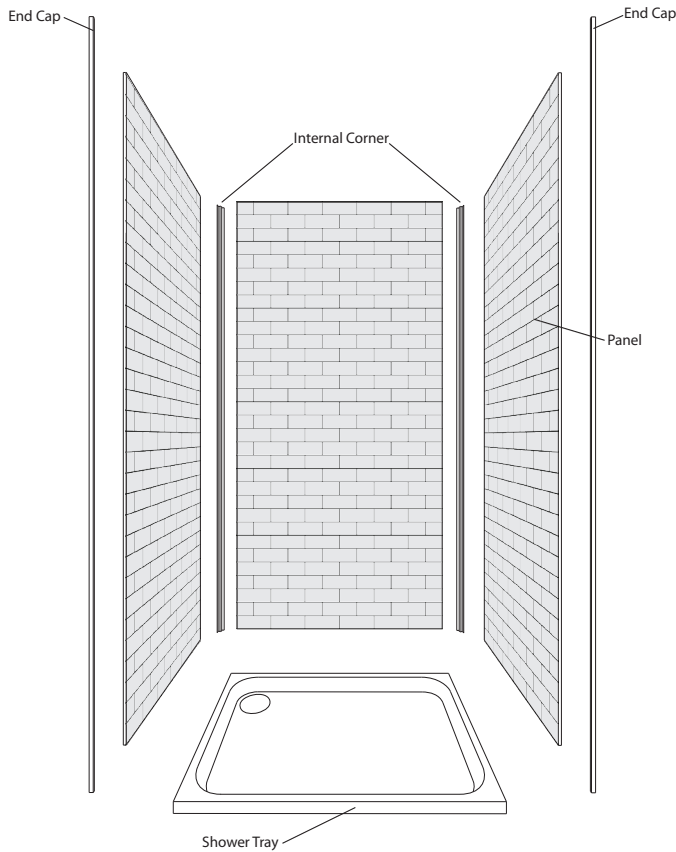

1. Peel back the protective film about 25mm from both the vertical edges of the panel.
2. Fit both of the internal corner profiles onto the edges of the panel by applying a bead of sealant into one channel of each of the profiles.
3. A 3-4mm gap should be left between the bottom of the panel and the top of the shower tray, this can be achieved by using packers which will be removed before sealing.
4. Apply adhesive to the back of the panel as detailed in Fitting Tips then position the panel against the wall applying even pressure over the surface to ensure a good bond.
5. Peel back the protective film about 25mm from the vertical edge of the side panel.
6. Repeat this on the opposite edge if an End Cap profile is required and fit the End Cap to the edge of the panel using a bead of sealant.
7. Apply adhesive to the back of the panel as detailed in Fitting Tips.
8. Apply a bead of sealant into the remaining channel of the Internal Corner profile.
9. Insert the exposed edge of the side panel into the internal corner at an angle ensuring that a good seal is achieved then swing the panel back into place against the side wall applying even pressure over the surface to ensure a good bond.
10. Repeat steps 5-9 for the remaining side panel.
11. Seal the bottom of the panels and any apertures required as detailed in the fitting tips section.

11. Straight Jointing Details

When panelling areas more than 1200mm wide an H section Profile should be used between the panels to ensure a more robust seal.

1. Apply a bead of sealant into one channel of the H section profile and fix to the edge of the first panel to be fitted.
2. Apply Panel Adhesive to the back of the panel and profile. Fit the panel in place by applying even pressure over the surface.
3. Screw Fix the exposed flange of the H section profile using M3 countersunk screws ensuring that the screw head is recessed as much as possible.
4. Apply a bead of sealant into the remaining channel of the H section profile then fit the next panel in place as step 2.

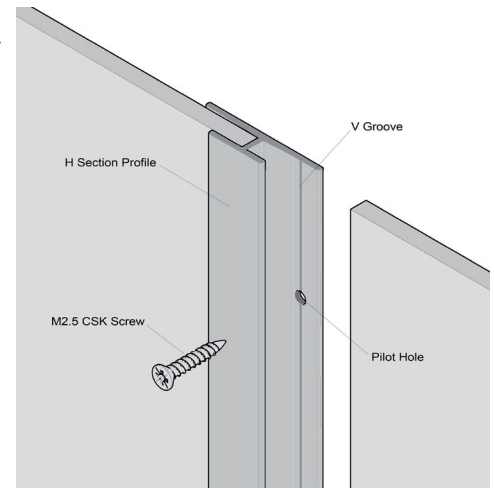

12. Bottom & Skirting Details

Depending on the type of installation there can be various options for finishing the bottom of the panel but in all cases it is essential that they are sealed adequately.

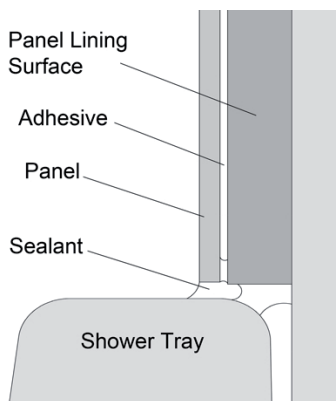

If the panels are being fitted above a bath or a shower tray, then these should be fitted first and sealed in accordance with the manufacturer's recommendations.

The panel lining surface should then be installed to provide the necessary step to allow the composite panel to be fitted 3-4mm above the horizontal face of the shower tray or bath. This gap should then be sealed ensuring that the silicone sealant is forced into the void.

In wet areas we do not recommend that the panels are fitted right down to the floor as sealing the joint can be extremely difficult.

A coved tile or PVC skirting is the preferred option with the panels fitted 3-4mm above. This gap should then be sealed ensuring that the silicone sealant is forced into the void.

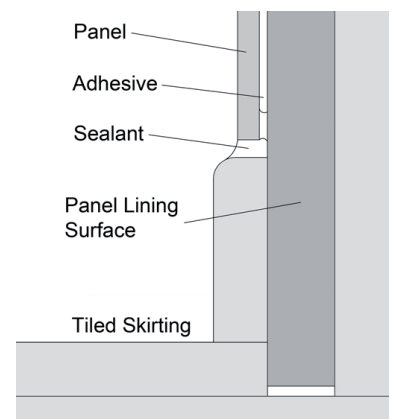

13. Window, Door & Finishing Details

There are various ways of finishing the panelling around windows and doors which will be dependant on the surface the panels have been fixed to, the window or door framing detail and the look you prefer.

Edges can simply be silicone sealed into existing frames or capped off with profiles. Corner joints can be formed using End Caps.

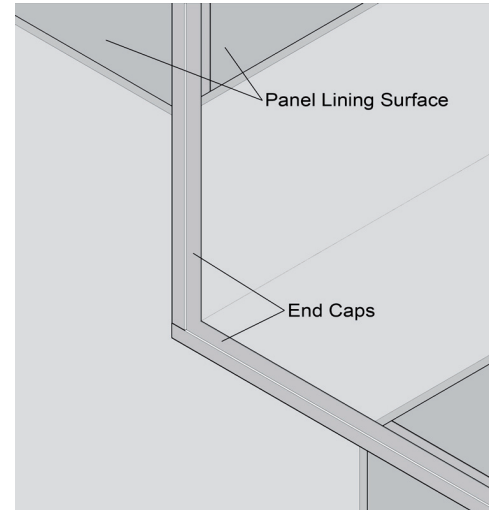

14. Cleaning

The panels can easily be kept clean with warm water and a very mild detergent. Where there are more stubborn stains, please contact the manufacturer's agent for more specific advice.

Under no circumstance should you clean your panels with an abrasive cleaner or any other abrasive material.

Shore Laminates Distribution Limited
Units 1-4 Inveralmond Cl
Inveralmond Industrial Estate
Perth
PH1 3TT

t. 01738 494 989
e. sales@splashwall.co.uk